

Top View

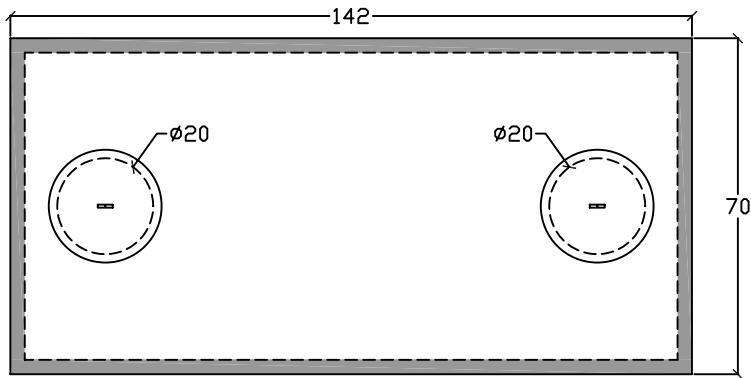

End View

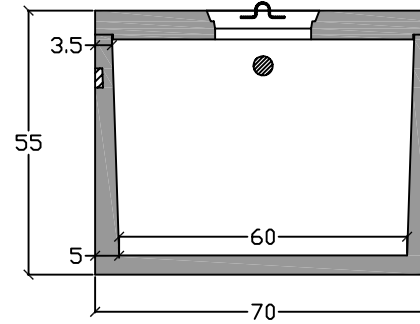

Specifications

Concrete: 5,000 psi minimum strength (28 day)

Reinforcing: Primary reinforcement will be top, side, and bottom #3 and/or #4 rebar (Grade 60) rebar.

Risers: Grade rings and manhole frames and covers sold separately.

Sealant: Sealant used in the seam of the tank will meet or exceed ASTM C990.

Pipe Penetrations: Inlet and outlets are fitted with seals that meet or exceed all ASTM C923 specifications.

Partition Wall: The partition wall, if present, is poured monolithically.

Installation: The tank hole is not to be more than one foot longer and wider than the tank. There shall be a minimum of 6" of 3/4" stone bedding in soil terrain and a 12" stone bedding in rock terrain. Do not install across path of vehicles or heavy equipment. This tank is designed for one hundred fifty pounds per square foot (150 lb/ft²) uniform loading on the top of the tank with a maximum backfill cover of 36" and a minimum of 6".

Tank Warranty: The C. R. Barger & Sons, Inc. septic tank when installed in accordance with manufacturer's instructions is warranted against defective materials and/or workmanship for 1 year from the date of delivery to the project site. Should a defect appear within the warranty period, C. R. Barger & Sons, Inc. will supply a new septic tank in replacement thereof. C. R. Barger & Sons, Inc. liability is limited to the value of the septic tank itself and specifically excludes the cost of installation and/or removal and consequential damages. Failure to comply with C. R. Barger & Sons, Inc. installation procedures and general notes will void warranty.

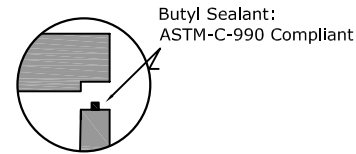

Side View

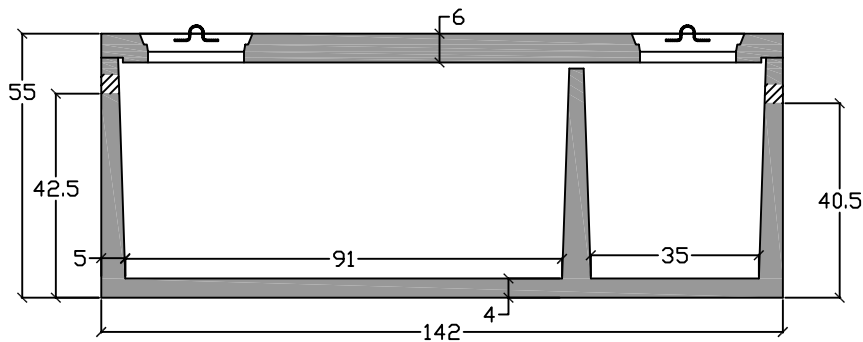

Baffle View

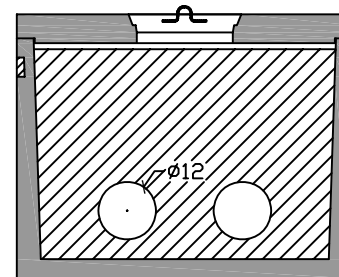

Manufactured by:
C.R. Barger & Sons, Inc.
 238 Mays Valley Road
 Harriman Tn 37748
Phone 865.882.5860 Fax 865.882.6394
 www.bargerandsons.com

General Notes:
 All vertical measurements are accurate within ± 1 inch on the tank. The lids can be moved and resized if necessary. Written specifications are available upon request.

Tank Type: Grease Trap 1250 Gallon	
Date: 3.242006	Approx. Weight: 13,000 lbs.
Drawn By: Eric Barger	