

Top View

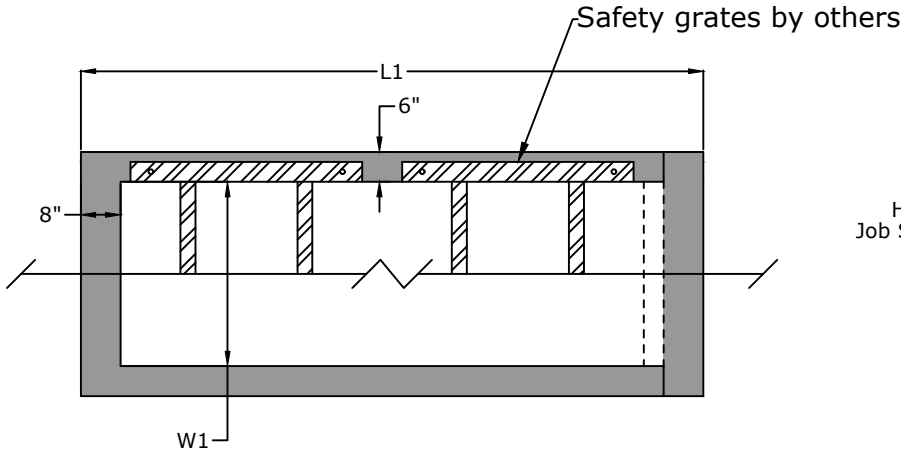

Front View

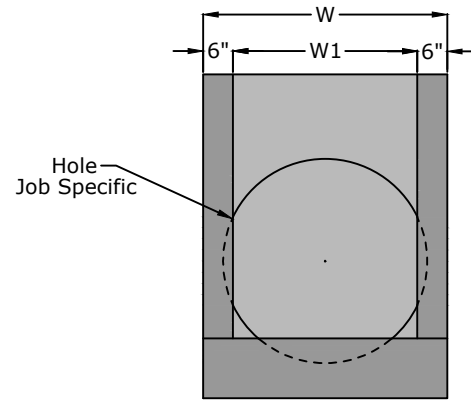

Side View

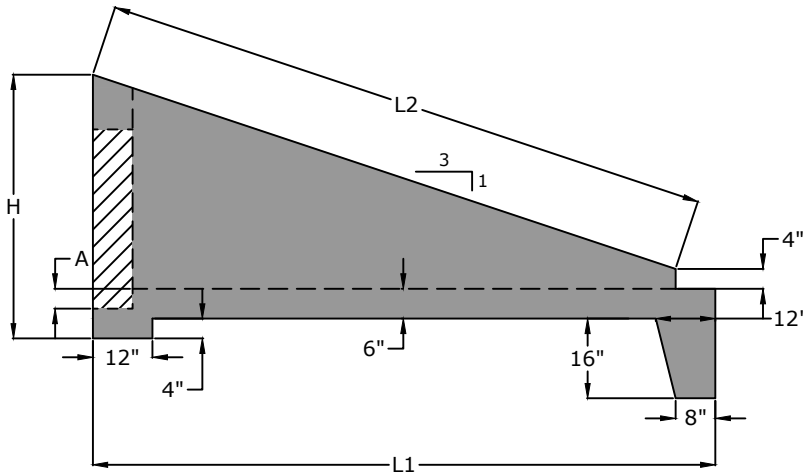

Dimensions (inches)

Pipe Culv. Dia.	H	L1	L2	W	W1	Wt. (lb.)
24"	45"	101"	98"	42"	30"	6,080

Hole Diameter	
Dimension "A"	
Pipe Size	

**Approved for Production**

Project: \_\_\_\_\_

Date: \_\_\_\_\_

Quantity: \_\_\_\_\_

By: \_\_\_\_\_



**Specifications**

**Concrete:** 5,000 psi minimum strength (28 day)  
**Reinforcement:** #4 rebar, Grade 60 per TDOT Standard D-PE-3B

**TDOT Type "U" Headwall  
3:1**

C.R. Barger & Sons, Inc.  
 P.O. Box 370 - Kingston TN 37763  
 Phone 888.882.5860 - BargerAndSons.com

Date: 8.132018

Drawn By: Eric Barger

Approx. Weight: See above