

Top View

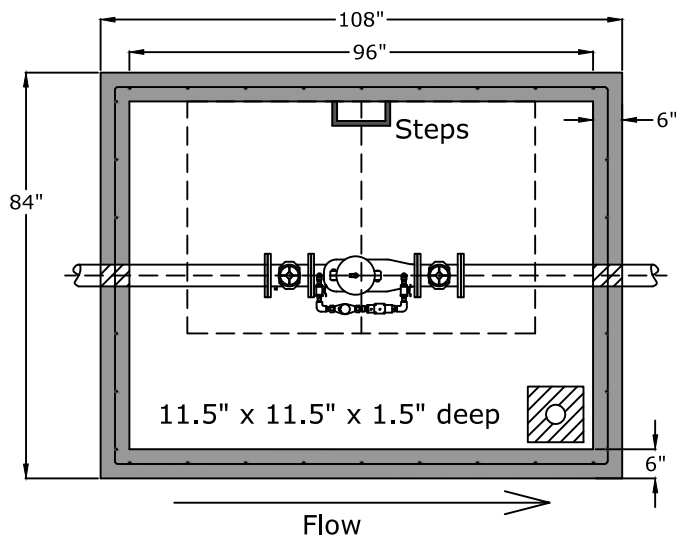

Weight (empty)

Top - 10,000 lb
Bottom - 11,000 lb

Side View

48" x 72" Aluminum Hatch

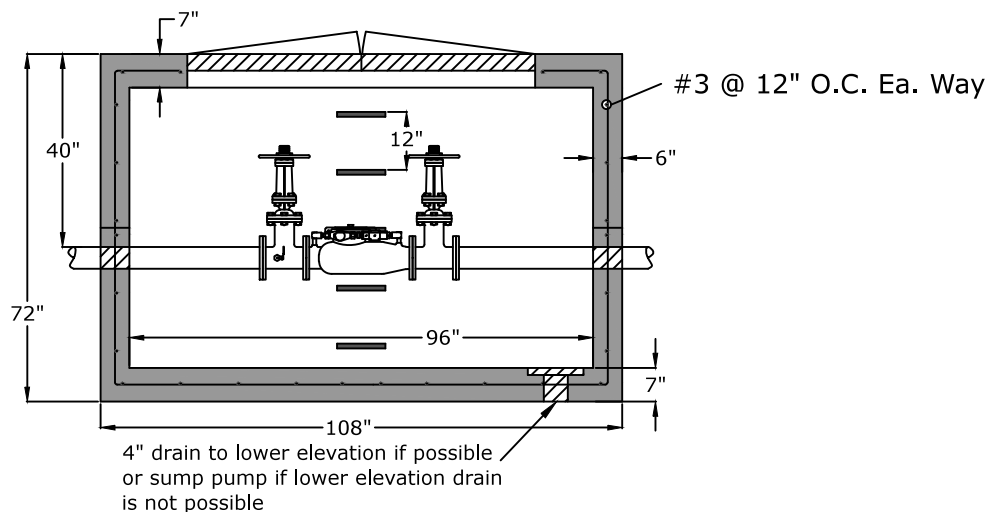

Joint Detail

Positive Lock Male/Female Keyway
+- 0.005" tolerance

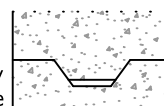

Approved for Production

Project: _____

Date: _____

Quantity: _____

By: _____

BARGER
PRECAST

P.O. Box 370 - Kingston, TN 37763
Phone (888) 882-5860

BargerPrecast.com

Specifications

- Concrete:** 5,000 psi minimum strength (28 day)
- Reinforcing:** Primary reinforcement will be a #3 rebar (Grade 60) rebar.
- Pipe Penetrations:** The inlet and outlet are fitted with solid seals or a grout connection. All pipe penetrations are placed according to job requirements.
- Pipe Stands:** Adjustable height pipe stands will be provided to support assembly.
- Sealant:** Sealant used will meet or exceed ASTM C990.
- Steps:** Aligned under hatch unless specified.
- General:** Meter vaults are not water tight structures unless specified by Barger And Sons.

8' x 6' Fire Meter Vault (6")
City of Springfield

Date: 10.052016

Drawn By: Eric Barger